

INSTALLATION AND OPERATION MANUAL

Units should be installed by properly licensed contractor(s) according to local code requirements.



BR130 (Door Closed)



BR130 (Door Open)



TW Kit

WARNING

TO REDUCE THE RISK OF FIRE, ELECTRIC SHOCK, OR INJURY TO PERSONS OBSERVE THE FOLLOWING RULES:

1. Use the unit only in the manner intended by the manufacturer. If you have questions, contact the manufacturer.
2. Unplug the unit before servicing or cleaning.
CAUTION: more than one disconnect switch may be required to de-energize the equipment for servicing.
3. Do not use in cooking area.
4. Sufficient air is needed for proper combustion and exhausting of gases through the flue (chimney) of fuel burning equipment that might be installed in the area affected by this equipment. If this unit is exhausting air from a space in which chimney-vented fuel burning equipment is located, take steps to assure that combustion air supply is not affected. Follow the heating equipment manufacturer's guidelines and safety standards such as those published by the National Fire Protection Association (NFPA), the American Society for Heating, Refrigeration and Air Conditioning Engineers (ASHRAE), and local code authorities.
5. Do not connect this unit to fume hoods or collection systems for toxics.
6. Installation work and electrical wiring must be done by qualified person(s) in accordance with all applicable codes and standards, including fire-rated construction codes and standards.
7. When cutting or drilling into wall or ceiling, do not damage electrical wiring and other hidden utilities.
8. This unit must be properly vented to the outside.
9. This unit must be connected to a properly grounded power outlet.

CAUTION

1. This unit is intended for general ventilating use only. Do not use to exhaust hazardous or explosive materials and vapors.
2. To avoid motor bearing damage and noisy and/or unbalanced impellers, keep drywall spray, construction dust, etc., off power unit.
3. This installation manual shows the suggested installation method. Any structural alterations necessary for installation must comply with all applicable building, health, and safety code requirements.



HVI
CERTIFICATION
PENDING

Location of the Unit

Before you begin

There are two general ways that the BR models can be installed. This manual covers duct hung installations. Please refer to the Thru-Wall instructions packed with the TW kit when installing units to an outside wall. Read all instructions before installing the unit. Also review supplemental instructions for the Thru-Wall kit if used. Carefully unpack and inspect the unit for shipping damage. Open the access cover and remove the duct collars and packing materials. Attach the two duct collars with the screws provided in the plastic small parts bag.

Select a location so that

- ◆ The unit is hung on the furnace or air conditioner return trunk line.
- ◆ The two ducts to the outside are kept as short as possible with few gentle bends. Keeping all ducts as short and simple as possible provides the best performance from the system. Shorter duct runs help assure that the system is balanced; the amount of air brought in is equal to the amount of air exhausted. Unbalanced flow can cause poor performance from the unit and may even result in frosting of the core during extremely cold weather.
- ◆ The fresh air intake vent from the outside is placed a minimum of ten feet from any other exhaust vent.
- ◆ The power cord reaches an electrical outlet.
- ◆ The front cover can be opened to allow cleaning the core and filters. **Provide at least 24" of clearance at front of unit for service access to the blowers, filters and exchanger core.**

It is recommended that the BR units be used with standard furnace air handling equipment with velocities not exceeding 750 fpm at the point in the return air duct where the BR unit is attached. An alternate field measurement would be to locate the BR unit where the static pressure measurement does not exceed -0.2 inch. If the air handling system is high velocity or high pressure then the EV Series of products by RenewAire is recommended.

If a basement area is not available or practical, use other mechanical room space such as a closet, garage, storage, or accessible attic or crawl space.

NOTE: If you wish to install the unit in an attic or other unconditioned space, you may need to use special installation techniques such as insulating all connecting ductwork. **Attic installations are allowed for residential applications only. When installed in an attic, the maximum installation height of the unit is 3 feet above the ceiling below.**

Mounting the Unit on Ducting

The unit can be mounted on a return duct in various orientations. It can be attached to the bottom of the return duct in lengthwise or crosswise orientation. It can be attached

to the side of the return duct. The different orientations are shown in the following figures.

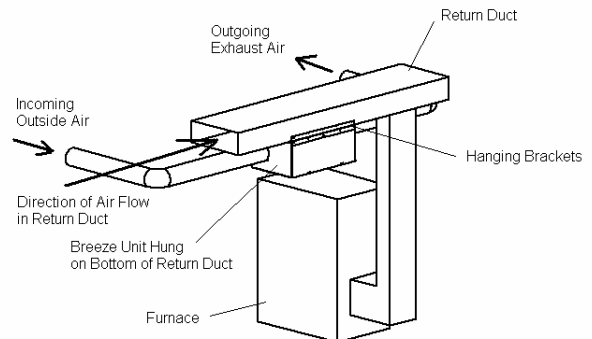

Figure 1. Bottom-Hung Lengthwise

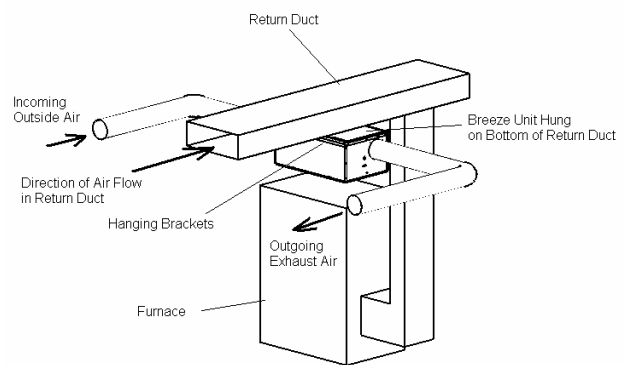

Figure 2. Bottom-Hung Crosswise

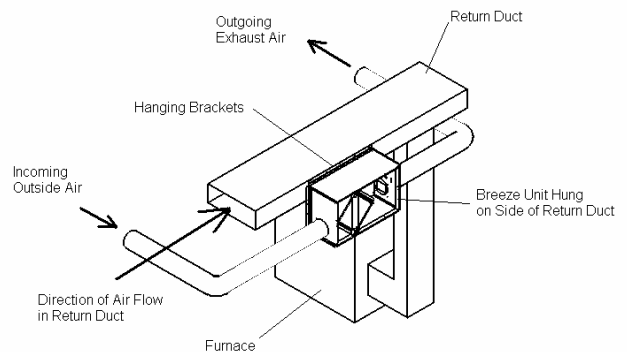

Figure 3. Side-Hung

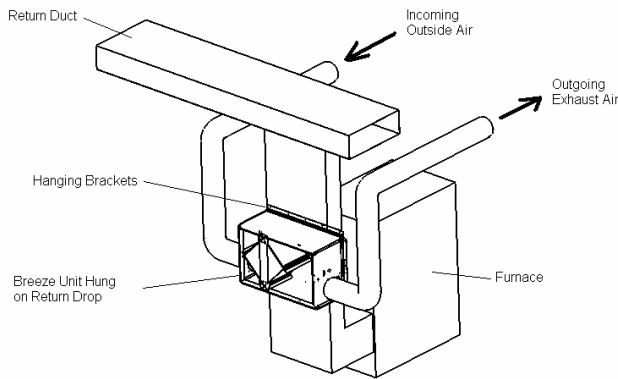

Figure 4. Return Drop Hung

Mount the unit hanging bracket to the unit. Attach the hanging bracket to the duct work. Make sure the unit orientation provides for proper airflow direction in the return duct. Refer to the air flow direction label on the unit. Using the template provided cut a rectangular hole in the duct work. To add rigidity to the duct, bend the edges of the hole into the duct as flanges. Check the gasket on the back of the unit to insure it is free of tears and rips. Add the long piece of gasket provided in the hardware kit to the back of the unit to form a rectangle with the other three pieces of gasket already applied. Lift the unit and connect the hanging bracket on the unit into the hanging bracket on the duct work. **Use caution and an assistant when installing the unit overhead.** Swing the unit into position and verify its fit. Attach the unit end flanges to the duct work. Now fasten the crosswise bracket to the duct work and then to the unit. The smaller crosswise bracket may need to be installed after the lengthwise bracket if one of the unit flanges cannot be attached to the return duct. Make sure the screws used are properly selected for the loads and substrate involve.

Note: All the provided brackets should be installed surrounding the opening between the unit and return duct.

Exhaust & Outside Air Ducts

The Exhaust Air Duct and the Outside Air Duct connect the unit to the outside. Flexible insulated duct is typically used.

For duct hung applications, the exhaust outlet and fresh air inlet on the outside of the building should be at least ten feet apart to avoid cross-contamination. Keep the length of the two flexible ducts roughly equal and as short and straight as possible. Normally, six inch insulated flexible duct is used. Band or tape inner duct liner to inner flange of appropriate collar. Drive a sheet metal screw through liner to secure duct spiral wire to collar. Straighten insulation, and slide outer duct jacket onto the outer flange of the duct collar. Secure with band or tape.

If duct runs are exceedingly long (over 10 feet of flex duct for 130 CFM) or have excessive bends or elbows or if maximum

air flow rates are required, eight inch insulated flexible duct should be used. The outer flange of the duct collar can be used for both the inner and outer jacket of the flexible duct. Care must be taken to insure that the duct is securely fastened and sealed to the duct collar. Ducts connecting the unit to the outside must be insulated with sealed vapor barrier on both inside and outside of the insulation.

The inlets and outlets should be screened against insects and vermin and shielded from the weather to prevent the entry of rain or snow. The exhaust outlet should not dump air into an enclosed space or into any other structure.

CAUTION: The fresh air inlet should be at least ten feet away from any exhaust such as dryer vents, chimneys, furnace, and water heater exhausts or other sources of contamination or carbon monoxide. Do not locate the fresh air inlet where vehicles may be serviced or left idling. Never locate the fresh air inlet inside a structure.

Mounting the Unit Thru-Wall

As another installation option the Breeze unit may be mounted directly to the inside of an exterior wall. The Thru-Wall kit must be used for this application. Refer to Thru-Wall instructions packed with the TW kit.

Mounting the Thru-Wall Kit

The Thru-Wall Kit, or TW, consists of two hoods, insulated metal ducts, an interior mounting plate, and small air seal gasket. See Figure 5. The interior plate is attached to the interior of the wall. Using the holes in the plate as a reference cut 6" holes to the outside allowing for a downward tilt to the outside of 1/2" for 12" of duct length. The insulated ducts are slid through the holes from the inside of the building. Bend over the tabs at the ends of the ducts on the outside of the building. These tabs can be attached to the building to keep the duct in position.

Duct length must be adjusted by cutting the duct to size. Allow a maximum of 1/2" of duct to extend past the interior wall covering.

Attach the wall caps to the exterior of the building. The wall cap with a rain guard is for the fresh air duct and the small wall cap without rain guard is for the exhaust air duct. Install appropriate flashing and sealing around the wall cap flanges to prevent moisture penetration into the building structure.

See instructions packed with the TW kit for more information.

Electrical Controls

WARNING: Danger of Electrical Shock When Servicing an Installed Unit. ALWAYS DISCONNECT POWER SOURCE BEFORE WIRING OR SERVICING.

NOTE: Proper Wiring Size Selection and Wiring Installation Is the Responsibility of the Electrical Contractor.

NOTE: Electrostatic discharge (static electricity) may have an adverse effect on the control board. Use proper grounding techniques when handling the control board.

Automatic Proportional Runtime Control

All installations include a Primary Operating Control on the unit to ensure appropriate operation of the system. The control terminal on the unit must be connected to the furnace/air conditioner and/or thermostat only for proper operation. The thermostat and furnace/air conditioner control circuit must be Class II circuits. See Figure 6 for a wiring diagram.

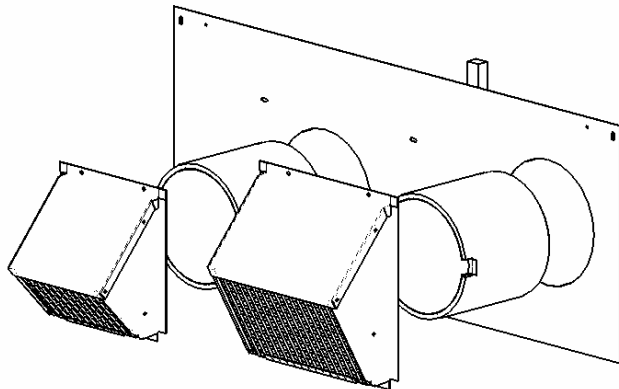

Figure 5. Thru-Wall Kit

Inside Ductwork System (For Wall Mounted Units Only)

Collect Stale Air from the House

Locate stale air return grills (RA) in rooms where moisture and odors are generated: stale air returns (which pick up stale household air to be exhausted) should be located in bathrooms and the kitchen. A central location such as a hallway is also acceptable but won't clear humidity and odors from baths and kitchens as rapidly.

Connect Fresh Air from the Unit to the House

Use a five foot section of flexible insulated duct to connect the unit to the return air duct at the port labeled *Fresh Air (FA)*. Note that the flex duct is not required for the room air connection (RA). This will cut noise transmitted from the unit. Stretch the flex duct tightly in order to maintain good airflow.

For houses with forced-air heating and cooling systems

Most units are installed with the fresh air duct connected directly to a return duct for the main heating and cooling system. Be careful to connect the fresh air duct at least three feet from the return plenum to minimize suction from the furnace blower. A connection closer to the furnace may result in unbalanced flow and associated problems.

For houses without ducted heating or cooling systems

In most houses one or two fresh air grilles in a central part of the house provide effective distribution of the fresh air into the home, particularly when the stale exhaust air is picked up at several points. Because the fresh air is usually somewhat cooler than the household air, the fresh air supply grilles should be located in a traffic area like a hallway or stairway rather than in a sitting area.

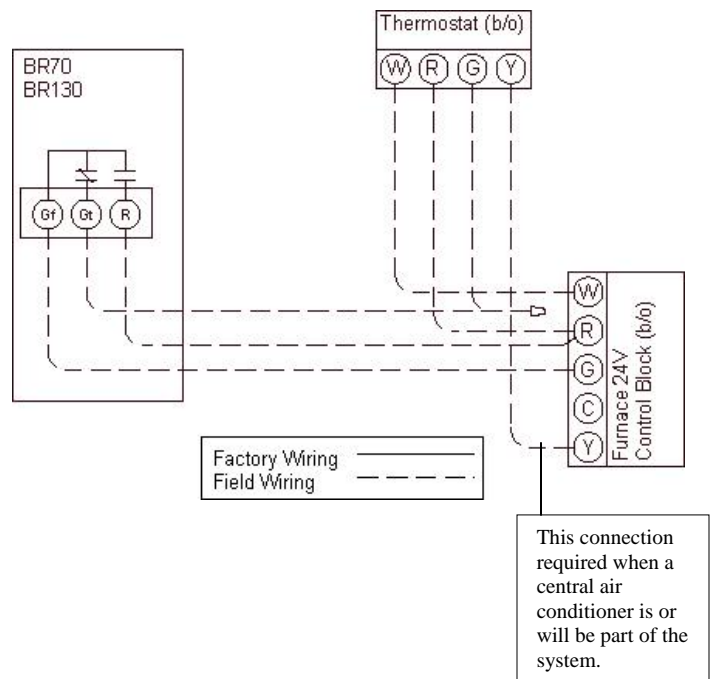

Figure 6. Wiring Diagram



Patent Pending

Maintenance Requirements

The Blower/Motor Package Needs No Lubrication.

If necessary vacuum clean the blower wheels at the same time you clean the face of the energy exchange element (yearly).

Clean Filters Regularly

Service filters every three months when the unit is in regular use or as needed to keep them reasonably clean.

1. Release cam latches and carefully swing access cover open. The cover may be removed by sliding to one side.
2. Pull the filters out.
3. Vacuum with a hose attachment.
4. Re-install filters.
5. Re-install cover and fasten cam latches.

NOTE: Filters should be replaced after they have been cleaned several times. The primary contact for replacement filters for your RenewAire unit is the installing contractor. As an alternative, you may wish to produce your own filters following these instructions:

Filters may be cut from a sheet or roll of ¾”–1” firm, spun polyester filter “hog hair” media or material, similar to the existing green filter in the residential unit.

The size of each filter (2 required per unit) is listed as follows:

BR70	7” x 10 ½”
BR130	10 ½” x 10 ½”

NOTE: Filters must be used or the energy exchange element will become blocked by dust. The filters supplied in the unit are usually able to keep the energy exchange element clean for many months. Finer filters can be used but must be cleaned more often.

Vacuum the Face of the Energy Exchange Element Yearly. Dust collects only on the entering faces of the energy exchange element. The interior of the energy exchange element stays clean even if the element faces are dust covered.

TO CLEAN THE ENERGY EXCHANGE ELEMENT:

1. Remove the filters (see above).
2. Vacuum the exposed faces of the energy exchange element with a soft brush attachment.
3. After servicing the filters, re-install them (see above).
4. Vacuum out dust from the rest of the unit case.

CAUTION: DO NOT WASH THE ENERGY EXCHANGE ELEMENT. Always handle the element carefully. Keep it away from water or fire to avoid damaging it. The energy exchange element can be replaced but is expensive.

Patent Pending

PRODUCT DATA

Energy Exchange System:
Certified Performance:

- ◆ Cross flow fixed-plate enthalpic heat exchanger core; engineered, proprietary resin-media composite. Moderates both temperature and humidity extremes.
- ◆ See HVI Performance Report

BR70

BR130

Airflow Range:
Rated Airflow:
Dimension:
Unit Weight:
Power:

- ◆ 30-80 CFM each air stream.
- ◆ 70 CFM at 0.2" external static pressure
- ◆ 27 1/8" long x 18 1/4" wide x 10 5/8" deep (Not including duct collars).
- ◆ 45 lbs.
- ◆ 0.08 HP, 1.0 amps, 85 watts at 70 CFM.
- ◆ 50-140 CFM each air stream.
- ◆ 130 CFM at 0.2" external static pressure
- ◆ 30 7/8" long x 18 1/4" wide x 13 3/8" deep (not including duct collars).
- ◆ 55 lbs.
- ◆ 0.1 HP, 1.3 amps, 123 watts at 130 CFM.

BR70

BR130

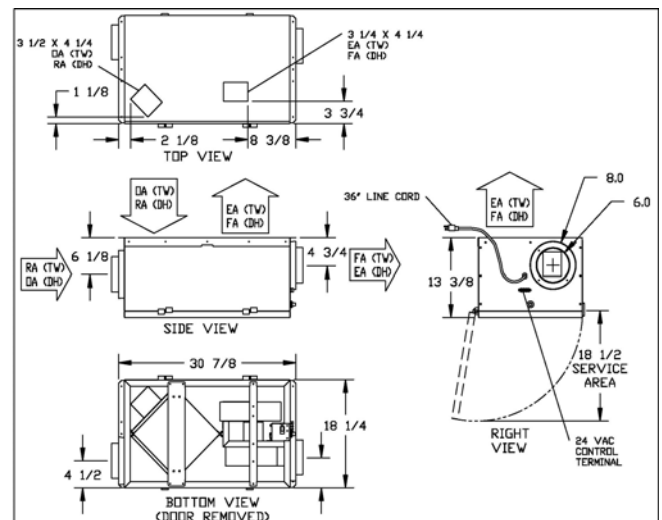
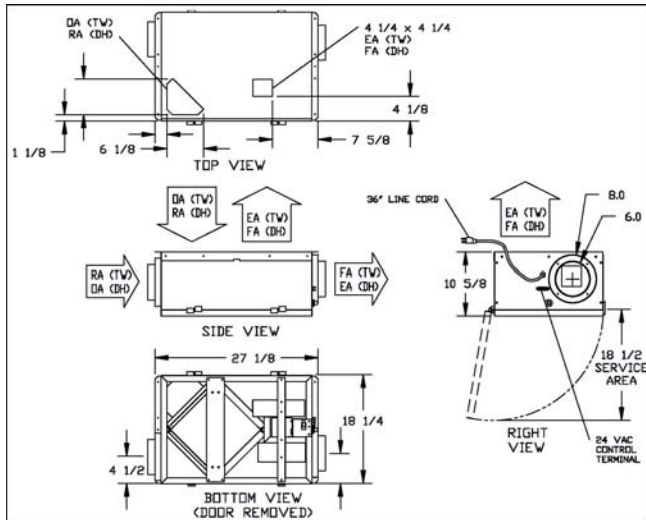

EA: Exhaust Air to outside
 DA: Outside Air Intake
 RA: Room Air to be exhausted
 FA: Fresh Air to Inside
 TW: Through wall
 DH: Duct hung

Access Cover:

- ◆ Front panel opens to provide access to filters, blowers, and heat exchanger. Snap latches and hinges provided for easy service.

Insulation:

- ◆ One inch foil-faced fiberglass throughout. Additional 1/4" foam insulation on access panel for thermal and sound insulation.

Duct Connections:

- ◆ Insulating double collars with 6" and 8" round connections for flexible or rigid duct work.

Mounting Options:

- ◆ Unit may be mounted to duct or wall using integral mounting flange with hanging bracket kit provided.

Blower/Motor:

- ◆ A single high efficiency PSC motor directly drives two centrifugal blowers for quiet operation.

Electrical:

- ◆ 115 Volt, 60 Cycle, single phase. Control: 24 volt, transformer and relay provided.

Filters

- ◆ Cleanable polyester air filters for both exhaust and fresh air streams.

Defrost:

- ◆ Passive frost-free design under most residential conditions.

Warranty:

- ◆ Ten year limited warranty on heat exchange core; two year limited warranty against defects in material and workmanship on all other components.



Parts List BR70 / BR130

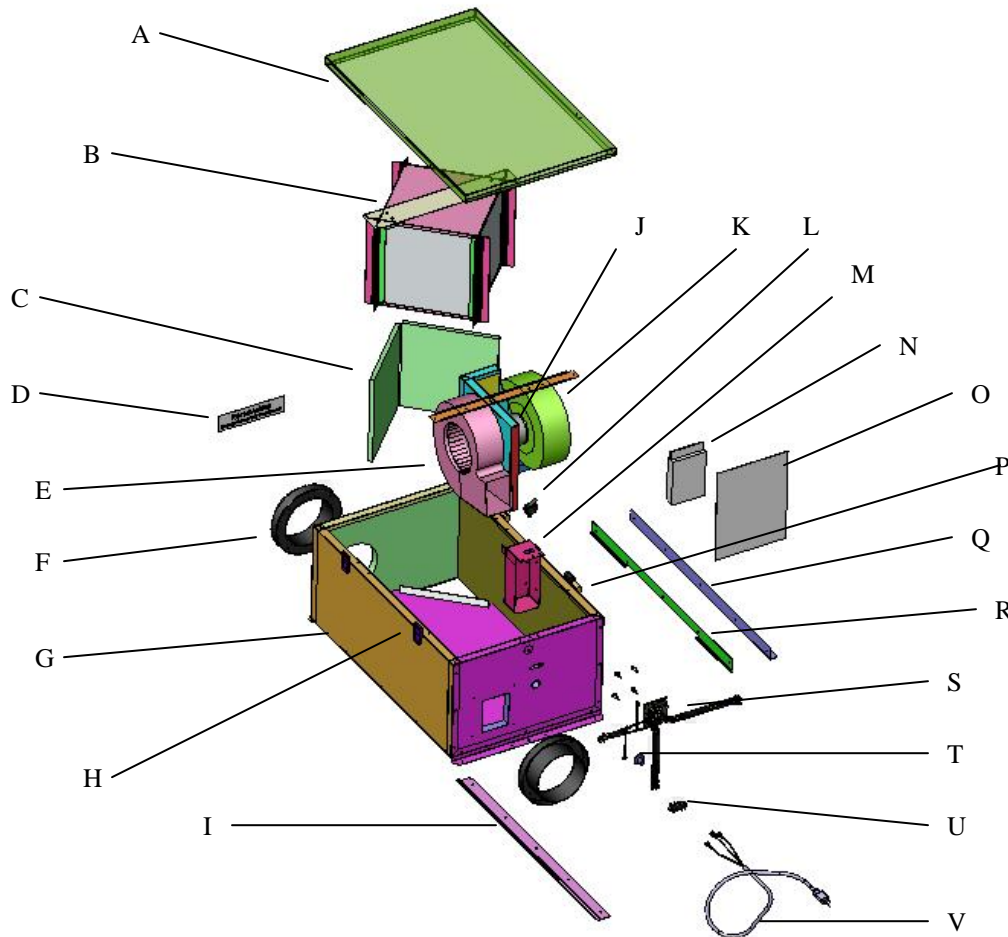

Description

Part number

	BR70	BR130		BR70	BR130
A. Door Assembly	990010	990007	L. Interlock Switch	102313	102313
B. Core assembly	990006	990004	M. E-Box	140086	140086
C. Filter (set of 2)	990011	990073	N. Hardware Kit	990012	990012
D. Label	104053	104053	O. Literature Packet	990016	990016
E. Blower & Wheel, Divider Side	990041	990032	P. Hinge set (both parts)	102216	102216
F. Duct Collar (two required)	102206	102206	Q. Angle Crosswise Mount	140161	140061
G. Case, Insulated	990001	990000	R. Unit Hanging Bracket	140131	140031
H. Latch set (both parts)	102217	102217	S. Control Board w/pot. and standoffs	990013	990013
I. Duct Hanging Bracket	140132	140030	T. Potentiometer Knob	140058	140058
J. Motor	102288	102288	U. Terminal Strip	140039	140039
K. Blower & Wheel, Motor Side	990051	990030	V. Line Cord w/Bushing	990014	990014
Blower Subassembly	990050	990034			



Patent Pending

Purpose of an Energy Recovery Ventilation (ERV) System

Many modern homes are built air-tight for energy efficiency and comfort. The result is that natural air infiltration rates are often too low to provide acceptable indoor air quality. The solution is to use an ERV to remove gaseous pollutants like: carbon dioxide, smoke, radon, odors, winter-time excess humidity, formaldehyde and other chemicals. The removal of dust and other small particles from your home is not the primary function of an ERV.

When should you use your ERV?

Use your ERV when windows are closed and you need to ventilate. When the outdoor air is warmer or cooler than comfortable, the ERV will allow a quieter, more secure home with the windows closed and will also save energy.

How much ventilation is right for you?

Different households require different rates of ventilation, depending on the pollutants found in each home. It is generally not practical to determine the exact amount of ventilation a specific home will need. The American Society of Heating, Refrigeration and Air Conditioning Engineers (ASHRAE) has developed minimum ventilation guidelines (see chart below) based on either the size of the house or the number of occupants (bedrooms), Breeze will automatically provide this rate every hour.

Smokers will generally need about double the usual ventilation rate to provide reasonable air quality. The presence of radon will also generally suggest a higher ventilation rate and other system modifications.

These guidelines are a starting point. As long as the pollutants you are concerned with are detectable (like water vapor or odors) your nose can be a good guide, and you may find that fewer hours of operation will be sufficient.

Elimination of household moisture when first operating an ERV.

In general, when the ERV is first turned on at the beginning of the heating season (or when first installed), it will have to run full-time for several days to stabilize indoor humidity levels. Set the control to the "100%" position for several days if you have a problem with excess humidity.

Using an ERV with air-conditioning.

An ERV works very well with air-conditioning, because its enthalpy-transfer core will reduce the amount of moisture in the outside air that is brought in. As is true during the heating season, ERVs should be used only as needed to provide good air quality.

An air-conditioned home in the summer is generally dryer than the outside air and the unit will work to remove excess humidity from the outside air before it enters the home. ERVs are the preferred way to ventilate during the air-conditioning season because it brings in less moisture than any other ventilation method.

Minimum Run Times (Ventilation Rates)

% Run Time	Square feet living space to provide 0.35 Air Changes/Hour		Number of Bedrooms 15 CFM/Occupant	
	BR70	BR130	BR70	BR130
10	150 ft ²	257 ft ²		
20	300 ft ²	514 ft ²		
30	450 ft ²	771 ft ²		← 1
40	600 ft ²	1028 ft ²	← 1	← 2
50	750 ft ²	1285 ft ²		← 3
60	900 ft ²	1542 ft ²	← 2	← 4
70	1050 ft ²	1799 ft ²		← 5
80	1200 ft ²	2056 ft ²		
90	1350 ft ²	2313 ft ²	← 3	← 6
100	1500 ft ²	2570 ft ²		